

Design Guidelines for Practical Near Field Line Arrays

James R. Griffin, Ph.D.

Unless otherwise noted, all information herein is protected by U.S. and international copyright laws. You may quote or copy this material for non-commercial personal use. You may not copy this material to other websites unless permission is obtained from me. You may not use the information herein for commercial applications unless you obtain agreement from me.

Contact Information:

jrgriffin@cookeville.com

James R. Griffin, Ph.D.
P.O. Box 49515
Cookeville, Tennessee 38506
USA

Design Guidelines for Practical Near Field Line Arrays

James R. Griffin, Ph.D.

It is widely recognized that tall columns of speakers that comprise a line array have significant benefits when properly implemented. The line source principle has these benefits:

- Contours the vertical sound dispersion such that floor and ceiling reflections are minimized
- Maintains a wide listening area with room filling, nearly constant sound intensity
- Provides exceptional dynamic range and linear performance

In most practical line arrays a two-way system is established by placing a vertical line of small woofers that operate across the lower frequency range. This line crosses over to a vertical line of tweeters that covers the higher frequency range. Often subwoofers would augment the lowest frequency range if very low in-room response is desired.

Small multiple drivers in a two-way line array with parallel/series connections have these advantages:

- Provides higher power sound pressure levels (SPL)
- Reduces distortion as power is dispersed among several drivers
- Enables higher power handling to be attained

A number of line array designs exist in both professional audio and home audio implementations but very little specific information exists for do-it-yourself implementations. While many of these designs have excellent performance, the professional audio designs are directed at full auditorium coverage and operate in both near and far fields. The commercial line arrays for home usage can be characterized as very expensive and well beyond the means of most audiophiles. In this paper we will derive design criteria that will result in a practical line array that can be built by an advanced speaker builder. We will not cover well known aspects of loudspeaker design but rather focus on the unique attributes of line array design.

Near and Far Field Definitions

All speakers produce sound in both the near field (close to the speaker) and the far field as distance is increased. The near and far fields are also known as, respectively, the Fresnel and Fraunhofer fields. Conventional point source speakers generate a spherical wavefront (see Figure 1A) and they place the listener entirely within the far field while line arrays can locate the listener within either near or far fields. For a line array the near field is where the radiated sound resembles a vertical cylindrical wavefront (see Figure 1B) which transitions in the far field to spherical sound radiation. To further visualize these differences, Figure 2A depicts a side view of the vertical radiation from a line source and illustrates the near and far field regions. The source height is, h , the distance from the source is, r , while the near to far field transition occurs at distance, d . Within the near field the sound falloff within the room decreases inversely versus the

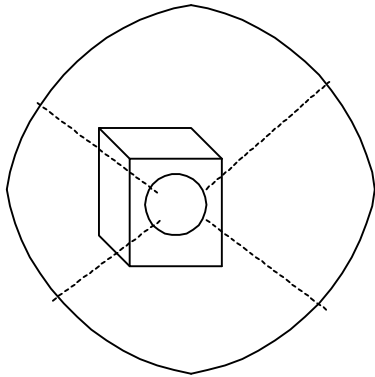

**Figure 1A -- Point Source--
Spherical Wavefront**

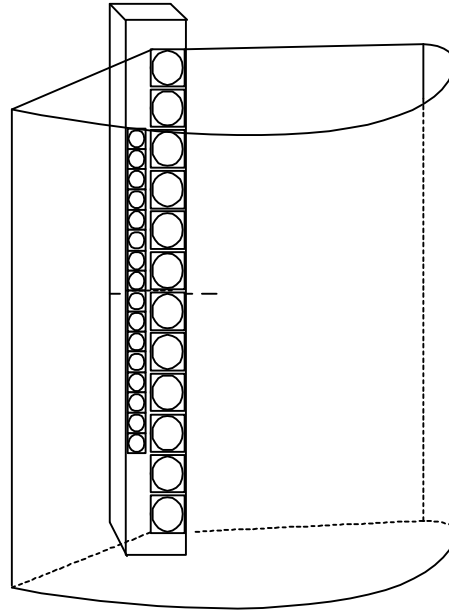
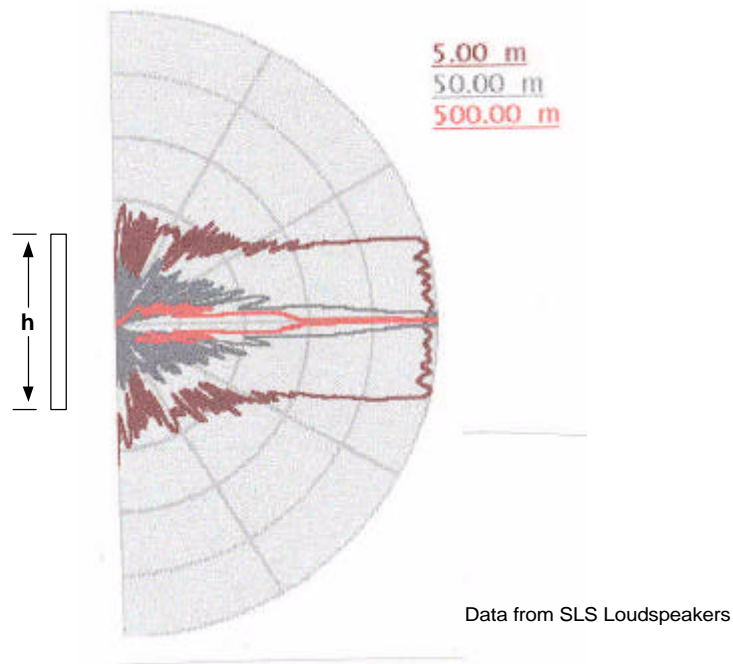
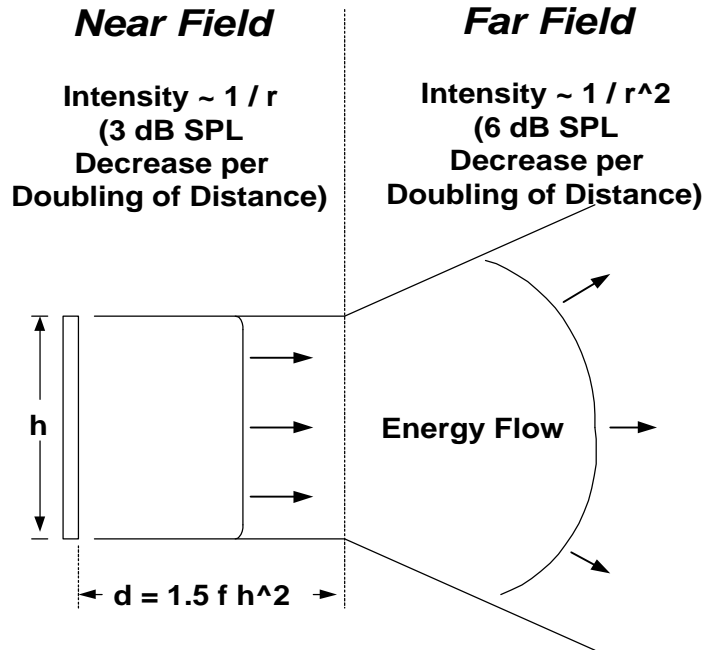

**Figure 1B -- Line Array--Cylindrical
Wavefront (Near Field)**

Figure 1. Point Source and Line Array Wavefront Diagrams

distance or 3 dB per doubling of distance away from the speakers. As the radiation shifts to the far field, the sound decreases inversely with the square of the distance from the source or by 6 dB per doubling of the distance from the source. Notice also in Figure 2A how the energy flow differs between the near and far fields. In the near field the vertical radiation from the source extends perpendicularly from the line and virtually no radiation occurs beyond the extent of the array. Hence, little energy would reflect from ceiling and floor boundaries in the listening room. In the far field the energy flow is radial and expands as distance is increased so reflections from the boundaries occur. Figure 2B shows vertical polar diagrams of a 3 meters high line array at 12 kHz. Three measurement distances are illustrated at 5, 50 and 500 meters. Notice how the 5 m field pattern is very flat across the aperture of the array with virtually no radiation beyond the extent of the array. As the distance increases, i.e., 50 and 500 meters, the vertical angular coverage of the radiation patterns is significantly reduced but still illustrates the long projection throw of a line array. Hence, this line array would cover an audience within a large venue.

Our goal is to develop a line array loudspeaker system for the home that assures that the listener is in the near field as much as possible. We typically hear a combination of direct sound that transverses directly from the speakers and reflected sound that comes to us after reverberation from the walls, floor, and ceiling. But in the near field direct sound from the speakers dominates which lessens any room effects. Hence, near field listening is more akin to hearing the anechoic response of the speakers versus a combination of direct sound and any room reinforcement or cancellation. We will also realize side benefits such as an exceptionally wide soundstage and imaging if listening occurs entirely within the near field. Any blurring from reflected sound will be minimized.



**Figure 2. Line Array Near and Far Field Region Definitions (Figure 2A top)
Near and Far Field Polar Radiation Patterns (Figure 2B bottom)**

Finally, a vertical stack of point source drivers can act as a single elongated driver. If the individual drivers are all fed the same signal, then the driver stack would radiate an acoustic wave that approximates the performance of a single elongated driver under certain conditions. Hence, we have a tall cylindrical sound source as the sound field has been transposed into a vertical wavefront of sound. We'll derive the guidelines and rules that are necessary to produce the near field line array effect later in this paper.

Line Array Background

Much of the literature (see references [1] - [5]) on line array technology centers upon application for professional sound reinforcement applications. Typically, these applications must operate in both near and far fields. Far field sound radiation for line arrays is easily characterized by closed form equations and mathematical models as given by researchers (see [3] - [5]). These results lead to polar radiation plots and graphs that can depict the far field performance of line arrays. Of the early line array research and mathematical modeling reports, the Lipshitz and Vanderkooy paper (see [6]) was one of the first treatments that dealt with modeling arrays in both the near and far field situations. More recently, Urban, et al. [1] and Heil and Urban [2] adapt Fresnel optical techniques to the acoustics of line arrays. Their heuristic research yields a better understanding of the physical phenomena of how discrete sound sources approximate a continuous line source. Results from both near and far field analysis will be used in our line array design criteria.

In the literature (see Lipshitz and Vanderkooy [6], Urban, et al [1], Ureda [3], and Geddes and Lee [10]) several shortcomings of line arrays are cited. These issues, which have been raised by several researchers, are outlined in Table I. The line array design criteria will mitigate many of these issues.

Table I. Line Array Design Issues and Mitigation Techniques

Design Issues	References	Mitigation Techniques
3 dB per Octave Decreasing Frequency Response Slope for Monopole Arrays	[6]	<ul style="list-style-type: none"> ▪ Equalize variation via crossover adjustments for simulated and/or measured performance
Near Field Sound Pressure Response Undulations Because of Finite Length Lines	[1], [3], [6], [11]	<ul style="list-style-type: none"> ▪ Properly select line lengths to assure near/far field transition is greater than the listening distance ▪ Room effects (reverberation) mitigate some degradation
Comb Line Destructive Interferences for Circular Drivers Line Arrays	[1], [2], [3], [4]	<ul style="list-style-type: none"> ▪ Limit center to center spacing between drivers to less than one wavelength ▪ Use power tapering to reduce effect
Line Source Discontinuities Causes Off Axis Lobes for Slot Type Drivers	[1], [2], [3]	<ul style="list-style-type: none"> ▪ Maximize the Active Radiating Factor via driver selection and placement
Sound Bloom Caused by Unequal Vertical Sound Path Lengths Between Drivers and Listener in Near Field for a Flat Baffle	--	<ul style="list-style-type: none"> ▪ Use curved baffle to equalize sound paths ▪ Use precedence effect via vertical power tapering
Nonlinear Impulse Response	[6]	<ul style="list-style-type: none"> ▪ Inherent problem with line arrays

Parameter Selection and other Line Array Design Decisions

Line arrays have specific criteria for overall height, each driver line lengths, physical spacing between drivers, specific crossover frequency issues, computation of array sound pressure levels and impedances, and methods to prevent sound degradation. Figure 3 delineates the geometric parameters of concern to the line array designer. Urban, et al [1] derive line array parameters based upon Fresnel analysis (near field) techniques while Ureda [3] develops similar criteria but argues from far field methods. To comprehend the various line array design parameters, Table II has been prepared to detail these various elements. In the right most column the criteria from Ureda [3] is given while the next column to the left are the parameters from Urban, et al [1]. The recommended guideline column yields a specific set of parameters that are discussed in the subsequent text.

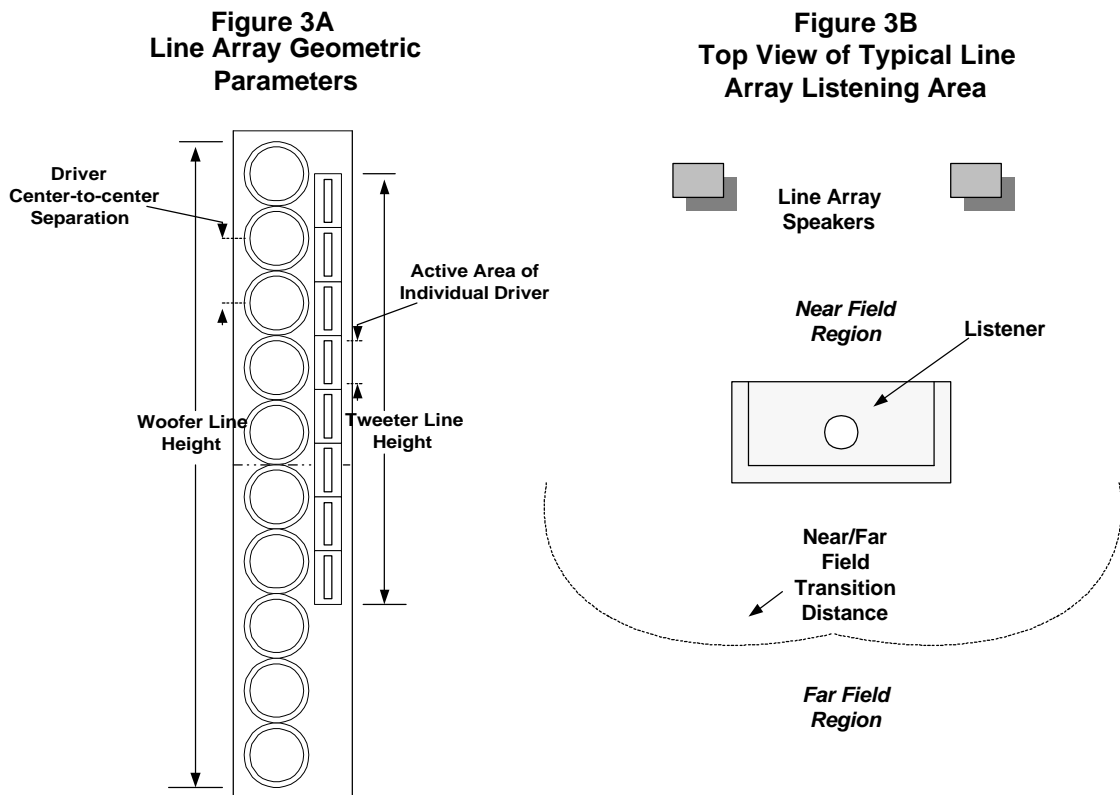

Figure 3. Line Array Parameters and Definitions

Table II. Line Array Design Criteria
(Units are meters and kilohertz)

Parameter	Recommended Guideline	Criteria from Near Field Analysis [1]	Criteria from Far Field Analysis [3]
Near/Far Field Transition Distance (d)	$d = 1.5 f h^2$ (See Figure 5)	$d = 1.5 f h^2 \sqrt{1 - 1 / (3 h f)^2}$ $d \sim 1.5 f h^2$	$d = 1.45 f h^2$
Height (Length) of Woofer and Tweeter Lines	Place Listener in Near Field (Use distance to near/far field transition) (See Figure 5 and Text)	--	--
Low Frequency Cutoff (f)	$f = 1 / (3 h)$ (Tweeter Line) $f = 1 / (9 h)$ (Woofer Line with Floor & Ceiling Aiding) (See Figure 5 and Text)	$f = 1 / (3 h)$	--
Center-to-center Separation Between Circular Drivers (at highest frequency)	$< \lambda$ (See Figure 8 and Text)	$< \lambda / 2$	$< \lambda$
Active Radiation Factor for Slot (Rectangular) Drivers	$> 76\%$ (See Figure 9 and Text)	$> 80\%$	Off Axis Impact of Gaps Presented

Near / Far Field Transition Distance or Critical Distance

To illustrate the sound pressure response versus distance for a line array first consider Figure 4 which depicts the SPL of a 4m high line source at 8 kHz (adapted from Ureda [11]). In the near field the response slopes downward at a 3 dB per doubling of distance (10 dB per decade) rate while the far field the response declines at a 6 dB per doubling of distance (20 dB per decade) rate. Notice the increasing undulations in the near field performance as the response transitions from near to far field. The near/far field transition distance is often defined as the critical distance at which direct sound from the source and reverberant sounds are at the same level (see Ureda [11]). The frequency response undulations versus distance are manifest with any finite length line array-- whether it is implemented as a single continuous source or with discrete drivers.

The near to far field transition distance is an important figure of merit for line array design purposes. In the literature Ureda [3] derives this distance from far field considerations while Urban, et al. [1] develops similar equations from geometric and numerical or Fresnel calculations. In Table II these relationships are given where near/far field transition distance is d (in meters), h (in meters) is the line height, and f is the frequency in kHz. The recommended equation for the transition distance is plotted in Figure 5 across the audio range for various line heights.

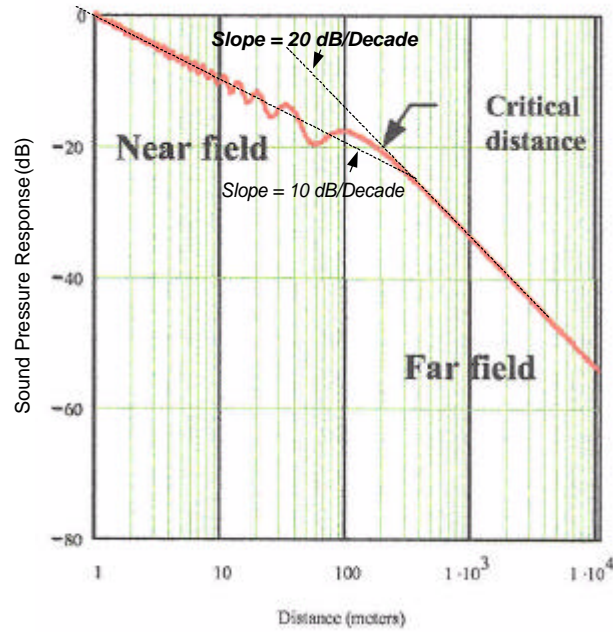

Figure 4. Line Array Sound Pressure Response Vs. Distance

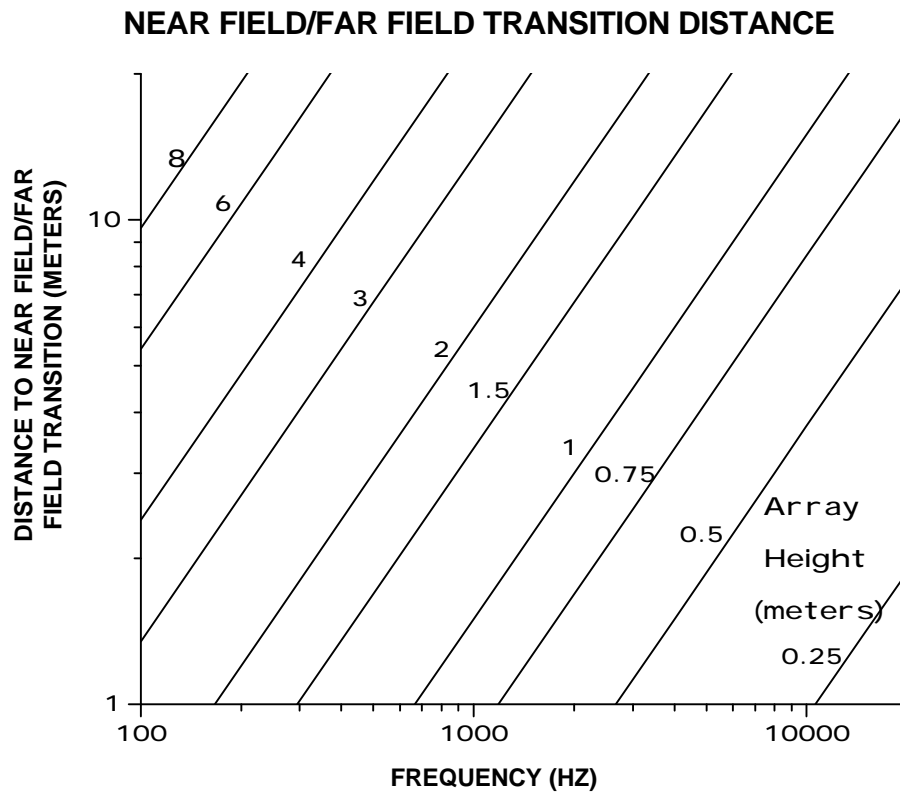

Figure 5. Near Field/Far Field Transition Distance

Woofer and Tweeter Line Height

Woofer Line Height. While an ideal line source that stretches to infinity would be an ideal woofer line, such an implementation is not feasible. For a truncated length—say a line array that extends from near floor to ceiling—you can approximate an infinite line within a room. From Figure 5 we can tradeoff selections of the line height, frequency covered, and the desired transition distance that locates the listener within the near field. But this tradeoff may not indicate adequate performance for the lowest frequency range. For example, given a 4 m (13.1') or greater near field/far field transition criterion and a 2 m (6.6') high woofer line composed of cone drivers, then the near/far field transition equation used for Figure 5 indicates that the near field range is satisfied for frequencies above 667 Hz. Below this low frequency limit the near field performance trends toward far field operation. However, for this situation we realize additional benefits from in-room reflections or reverberation that enhance the vertical angular dispersion of the array. Hence, the drivers in the array have in-room responses that will reflect from the floor and ceiling surfaces across the lower frequency range. These in-room mirror image reflections are shown in Figure 6. If the floor and ceiling have perfect acoustical

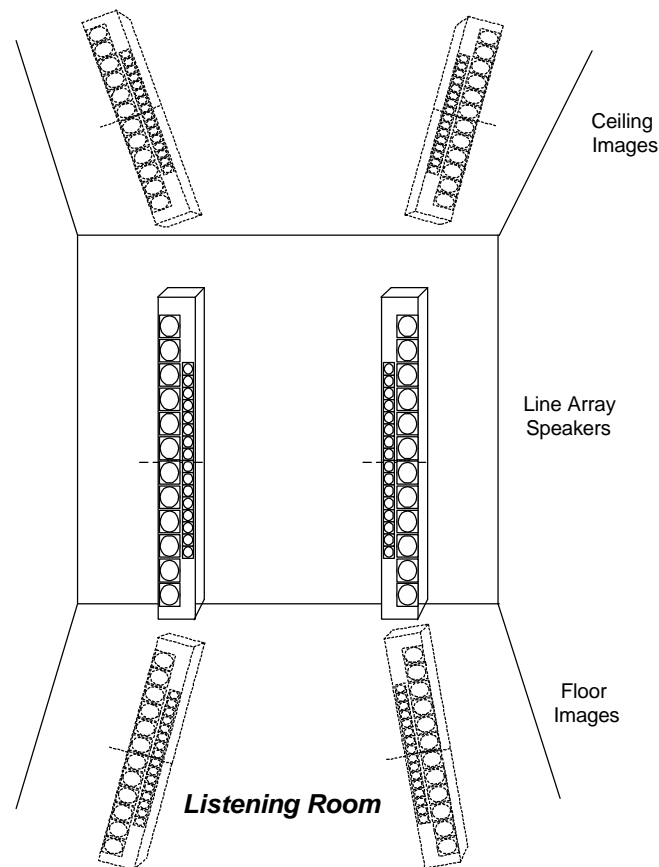

Figure 6. Low Frequency Floor and Ceiling Mirror Image Reflections

reflectivity, then these reflections would bounce back and forth between surfaces so that the line theoretically extends to infinity. Now perfectly reflective surfaces are not realistic so as a rule it is recommended that one assume that the line array length is extended by 3 times its height (the line height plus image reflections from both the floor and ceiling). Effectively, the two meters tall line will appear to be a 6 m (19.7') long line. Hence, this line would have near field array performance that extends to below 100 Hz at a 4 m (13.1') listening distance (see Figure 5). Naturally, these woofer line calculations in this example assume that the individual woofers in the line have low frequency responses that can extend below 100 Hz. Finally, combination of woofers into a line array may slightly extend the low frequency response versus a single driver.

Finally, best low frequency coupling to the boundaries occurs wherein the distances between either end of the line and the ceiling and floor are less than a wavelength, respectively. Typically, the woofer line length height needs to be greater than 70% of the room height for effective boundary coupling.

Tweeter Line Height. As for the woofer line length, the ideal tweeter line length would also extend from near the floor to the ceiling. Such a length would assure near field sound radiation for the entire room. Possible implementations would be a very long ribbon/planar tweeter or a large number of small dome tweeters if a floor to ceiling line length is desired. However, either of these implementations would be expensive.

To assist in the tweeter line length selection that will best balance between practicality and cost issues, we will evaluate these considerations:

1. **Minimum Near/Far Field Transition Distance.** From Figure 5 you can derive a specific height for the tweeter line by looking first at the lowest acceptable near/far field transition distance at the expected crossover frequency which is assumed to be the lowest operating frequency for the tweeter. From the plot the intercept point on the various line height contours then determines the minimum tweeter line length to project a near field beyond the transition distance. Note this distance varies directly with frequency so longer extension of the near field is observed as frequency increases.
2. **Listening Position Coverage.** Consider also the listening position and whether you desire to cover the sitting position (slightly less than one meter (39.4") above the floor at ear level) only or both standing (typically up to 1.8 m (70.9") height) and sitting positions. Hence, for many situations a tweeter line height would need to be greater than one meter to adequately cover both sitting and standing positions. Also note that for single ribbon or small ribbon/planar tweeter arrays any tweeter length significantly below the sitting listening position or above the standing position may not significantly contribute to the sound heard by the listener. If you listen while lying flat on the floor or are over two meters tall, then you may wish to appropriately increase the tweeter length.
3. **Radiated Power.** If the woofer and tweeter lines are significantly different in their length, then the total radiated power within the listening room may differ as the sound transitions from line to line. While power tapering of the woofer line may help balance the sound between the lines, adherence to the two criteria listed above will generally mitigate any sound perturbations.

From Figure 4 (see also the references in Table I) we remember that mathematical modeling studies show that finite line length arrays exhibit undulations in frequency response that show amplitude fluctuations versus distance from the source. Room reverberation (floor and ceiling images) will smooth out and extend the frequency response performance for the woofer line, while the tweeter line will typically benefit from reverberation from the side walls of the room. This reverb will lessen the effects of any unevenness in the frequency response.

As an example of a tweeter line length selection, consider that a 1.2 m (47.3") long tweeter line when operated at 3000 Hz will have a near/far field transition out to 5 m (16.4') from the source as indicated in Figure 5. Beyond 5 meters listening distance (at 3000 Hz) the sound field will trend toward a far field (6 dB per doubling of distance fall off rate). Also a 1.2 meters long line which if positioned from 0.6 m (23.6") to 1.8 m (70.9") would be sufficient to cover both sitting and standing listening positions. For frequencies above 3000 Hz, the near field extends well beyond 5 m.

Driver Separation

The goal in determination of the spacing between drivers in a line array is to position them so that you approximate a continuous line source as closely as possible. This would yield an constant phase front (isophase condition). We will consider three cases--circular (cone and dome) drivers, slot (rectangular) drivers, and ribbon/planar drivers.

Center-to-center Driver Separation (Circular drivers). We want our discrete driver array to approximate a continuous line source. This spacing is the separation between the centers of the adjacent drivers in the line and includes any mounting allowances and the flanges surrounding the drivers. In the limit the closest spacing would be dictated by the flange diameters of the drivers although some drivers have truncated flanges that would allow closer spacing. Two different solutions (Table I) for the driver separation guidelines are presented in the literature for circular drivers. These cases are:

1. Far Field. Ureda [3] uses driver directivity to determine that circular drivers need to be positioned within one wavelength center-to-center at their highest operating frequency. Wavelength is equal to the velocity of sound (344 m/s or 1130 feet/s) divided by the frequency. Directivity of the multiple drivers in the line increases until one wavelength spacing is reached and starts to decrease beyond this spacing. Figure 7 illustrates how the sound wavefront is created by a line array. Spacing less than one wavelength creates a constant phase front but comb lines start to form beyond one wavelength separation. At two wavelengths separation the first cancellation occurs. Directivity continues to decrease with more severe comb line effects as the spacing increases beyond two wavelengths.
2. Near field. Urban, et al [1] derives a more restrictive criterion of no more than a half wavelength separation between drivers at their highest operating frequency. Fresnel analysis is used and a disruption grid is used to shutter a continuous line source in their work. This analysis is based upon their desire to place any far field dips (nulls) in the angle off axis response of the array beyond $\pi/2$ (90 degrees). This assures that secondary (off-axis) lobes in the sound field are greater than 12 dB down from the on-axis response (main lobe).

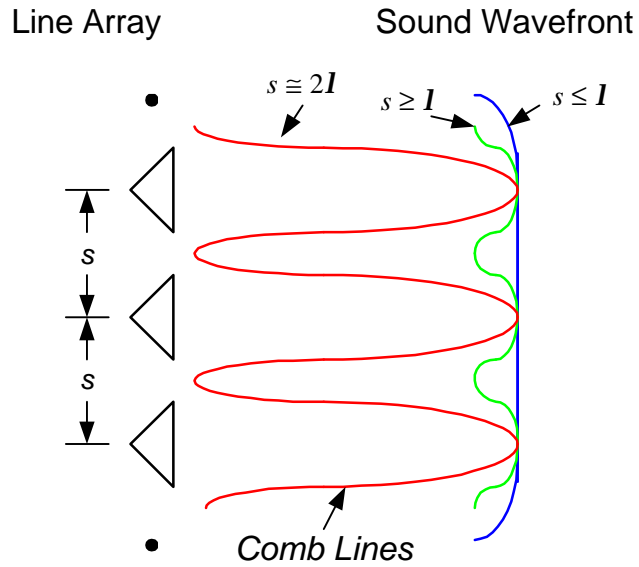

Figure 7. Side View of Line Array Showing Sound Wavefront Comb Lines

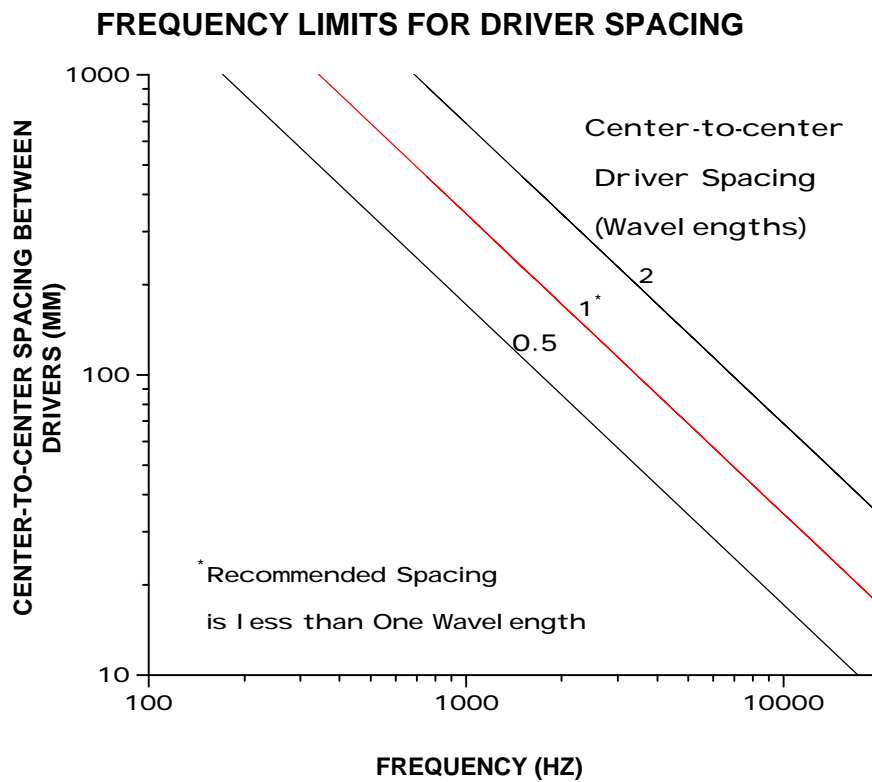

Figure 8. Center-to-center Driver Spacing

Figure 8 is a plot of wavelength versus frequency with lines shown for a half, one, and two wavelengths center-to-center spacing between drivers. Given these two different center-to-center criteria (half or one wavelength spacing), the practicality of the line array must also be considered before adoption of a specific guideline. For the line of woofers the highest operating frequency of this line is assumed to be at the crossover point. Hence, for one wavelength separation and if you use the Urban, et al [1] goal is to limit the off axis nulls in the far field, then off axis nulls would be as close as 30 degrees in the far field vertical plane. While a 30 degrees null in the far field vertical direction would be above or below the listener at typical listening distances, so likely this would be acceptable in most home line array usage as we assume that all listening is done in the near field which would minimize far field imperfections.

For the tweeter line very close center-to-center spacing is difficult to attain as very small circular drivers would be necessitated for either the one wavelength or especially the half wavelength criteria. Consider operation to 20 kHz where one wavelength is 17.2 mm (0.68") and a half wavelength is only 8.6 mm (0.34"). Without regard to their surrounding flanges, dome tweeters are available in 25 mm (1"), 19 mm (0.75") and 13 mm (0.5") diameters. Hence, with any mounting flange allowance at all, the one or half wavelength c-t-c criteria are very difficult—if not impossible—to satisfy at 20 kHz. But, if we relax the c-t-c criterion, more secondary lobes would appear in the 10 to 20 kHz frequency range. Fortunately, in this octave the ear is less sensitive (per Fletcher-Munson curves) so any secondary lobes likely would be less audible to the listener. Thus, if one wavelength spacing at 10 kHz is adopted as a compromise, then tweeter spacing would need to be 34.4 mm (1.35") c-t-c apart. While more off axis secondary lobes would be generated in the far field, small flange tweeters are available to meet this dimension. The tradeoff is possible sound degradation from comb lines near 20 kHz.

Active Radiating Factor (ARF) and Slot (Rectangular) Drivers. While the center-to-center spacing makes sense for circular drivers, another criterion proposed by Urban, et al [1] is most useful for slot or rectangular drivers arrayed in a line. Their application leads them to implement a high frequency driver that utilizes a waveguide acoustic lens on horn drivers. These rectangular drivers have sound fields that overlap. Earlier Ureda [3] demonstrated the impact of gaps with his far field analysis. These gaps have little effect on the primary on-axis far field sound lobe but at higher frequencies the side lobe structure changes materially with gap length. The lobes get wider and change position. Urban, et al. [1] derives a criterion based upon the ARF that is the ratio of the active radiating length of the driver to the total length that separates the actual active area of one driver to the active area for the next driver in the line. The separation distance includes both the flange edges plus any mounting offset between the drivers. The ARF is the total percentage of the active area in the array. For example, if the driver is a single, long rectangular driver then the ARF is 100%. Now if smaller rectangular drivers are stacked, then the ARF will be less and in practice may be in the 70 to 90% range. The specific value derived by Urban, et al. [1] is that ARF needs to be greater than 80%. Their analysis assumes that the rectangular drivers have sound fields that overlap each other. They relate the ARF value to a secondary lobe level of 12 dB down with respect to the main lobe in the far field. Figure 9 plots ARF versus various side lobe levels and also shows the impact on the radiated SPL. An ARF value of 50% would have side lobes equal to the main lobe and it would have 6 dB lower SPL (only half of the line is radiating) versus a continuous line of the same length. For a line array design wherein

ARF is greater than 76% would assure that the side lobe levels would be greater than 10 dB down. Power tapering can also be used to reduce far field side lobe levels if additional reduction is needed. To maximize ARF you should prevent any gaps between drivers in the stack, use drivers that have very small radiating surfaces, or trim the adjacent driver flanges so that spacing would be minimized.

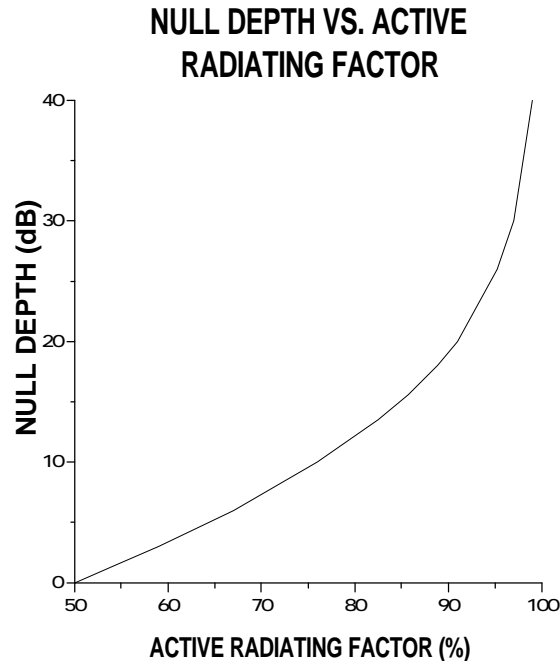

Figure 9. Null Depth vs. Active Radiating Factor

Ribbon/planar Drivers with Minimal Overlapping Dispersion. As pointed out earlier, the 80% ARF criterion stated by Urban [1] assumes overlapping vertical coverage from discrete drivers. This criterion does not strictly apply to short planar or ribbon sources. While a single, long ribbon can easily cover the listening area with a sound field that extends from sitting to standing listening heights, shorter ribbon/planar tweeters can be stacked in an array to cover the listening area. Each short tweeter in the stack would have full sound coverage within that flat, cylindrical shaped volume slice—150 mm (6") active height is typical--of the listening room. Below and above the active area of each tweeter (beyond the ~150 mm height) you may have gaps caused by the frames of the individual elements. Many of these sources have inherently limited vertical dispersion beyond the active area of each driver so little sound from an individual source overlaps the sound fields from adjacent drivers. Furthermore, any sound field overlap tends to diminish as frequency increases. This means that the efficiency gain of the array is minimized and only weak or no comb lines form. While you can often discern the amount of vertical sound field overlap for these drivers from manufacturer's data, measurements are needed for final design implementation.

The performance of a stack of short ribbon tweeters is akin to a long ribbon driver with intermittent gaps in the line. These gaps in the radiated sound from the stack are problematical but easily mitigated. If the radiated sound is measured vertically up and down an intermittent line of short tweeters within a one meter distance, response dips at

a frequency that corresponds to two wavelengths spacing between the active areas of adjacent elements would be noted in the vertical pattern. But, if this line probed at a greater distance, then these vertical response dips tend to fill-in as enough vertical dispersion radiates from the sources at very low angles from the ends of each driver's active region to cover these gaps. This effect is illustrated Figure 10. For example, one degree additional vertical radiation will fill-in 50 mm (2") gaps between adjacent drivers at a 3 m (9.8 feet) listening distance. Therefore, as the group of these tweeters are stacked in a line, the sound field wedges or slices from each tweeter become continuous and cover the entire vertical volume in your listening room from the bottom to the top tweeter. While these flat sound volumes have minimal overlap that may offer little improvement in overall SPL of the array, neither are significant comb lines formed.

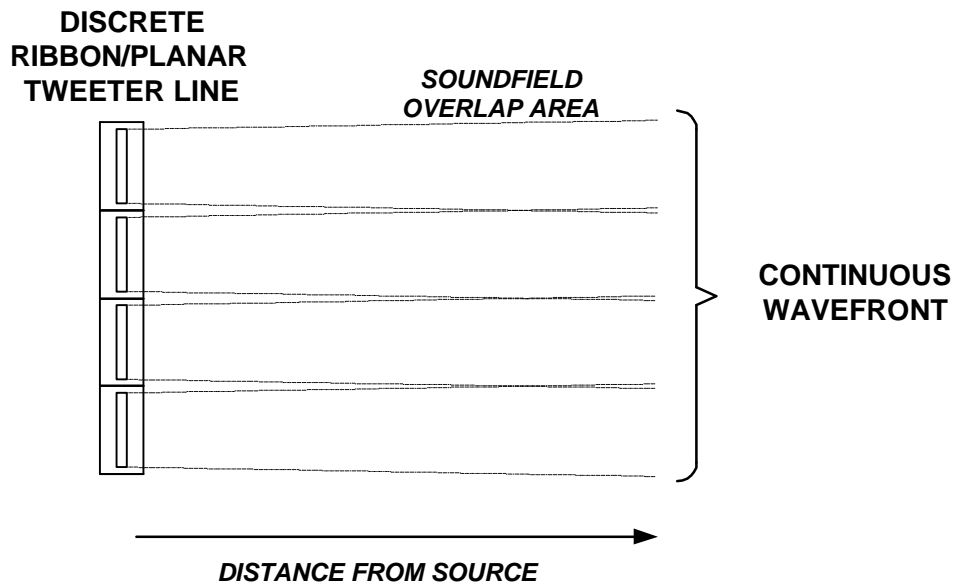

Figure 10 Discrete Ribbon/planar Tweeters Produce a Continuous Wavefront

Driver Selection and Crossover Considerations for Line Arrays

An abundance of drivers are available for incorporation into a line array. Numerous circular drivers—both cone and dome designs—can be procured with various diameters and prices. These circular drivers are available with sensitivities that can range into the low 90's dB SPL and many cover wide frequency ranges. Less common are long continuous ribbon sources (up to 1.9 meters or 75 inches). Unfortunately, none of the long ribbons can cover the entire audio frequency range and suffer from high cost (some >\$1500 per pair) and generally low sensitivity (<90 dB SPL). In contrast, short discrete ribbon and planar drivers can be arrayed and used as tweeter lines (typically above 1000 Hz). These short ribbons or planar drivers have sensitivities that range from 90 to 105 dB SPL. The ribbon or planar drivers can be purchased at prices that start at \$25 each for planar drivers and range up to \$500 per driver for more exotic ribbons. In general the arrayed sensitivity of the tweeter line should equal or be slightly greater than

the sensitivity of the woofer line. Hence, any overall sensitivity level adjustment between lines would usually consist of a small decrease in the tweeter line output.

While all of the normal speaker design considerations will impact the crossover frequency and slopes in a two-way line array, several additional constraints are necessary for line array performance. First, if discrete cone or dome drivers are used in the array then the comb line spacing criterion (less than one wavelength center-to-center separation at their highest frequency of operation) will influence the choice of crossover frequency. Just as driver perturbations (cone break-up, distortion, etc.) will help determine crossover filter slopes, comb line reduction will also merit design attention. The center-to-center spacing criterion in Table II likely implies both the woofer driver size and the crossover point between the woofer and tweeter line should occur. This observation is based entirely upon the geometry of the line array (spacing of the sources) without regard for performance of the drivers.

Consider, for example, if 130 mm (5.25") diameter drivers are used and are located 130 mm center-to-center spacing between each other (i.e., frames touching), then the frequency limit for increasing directivity is a wavelength spacing of 2582 Hz. The crossover to the tweeter line would need to occur no higher than this frequency. As we recall from Figures 7 and 8, comb lines will start to form above 2582 Hz with the first cancellation occurring at 5164 Hz. Severe comb line effects will be observed above 5164 Hz. As the crossover point approaches 2582 Hz, then a more aggressive 3rd or 4th order filter slope would likely be needed to yield acceptable performance. Quite often the natural acoustic response of the driver can be exploited to increase the effective crossover slope.

While the vertical separation of the drivers in each line of the line array plays a significant factor in the performance of an array, the horizontal spacing between the two lines needs to be minimized to reduce image shift as the sound transitions between the woofers and the tweeters. The design is essentially the same as if you designed a two drivers (woofer/tweeter) speaker that is placed horizontally. Care must be paid to minimize horizontal lobing from the side-by-side drivers. Some things to consider are the basic horizontal dispersion of the individual drivers that would ideally be similar and overlap to at least 30 degrees off axis. The two lines need to be located so that their horizontal center-to-center distance is less than a one wavelength at the crossover frequency. Finally, a higher order acoustic crossover may be necessary to minimize any driver interaction above and below the crossover point.

Another monopole line array crossover design consideration (see Table I) is how to equalize the inherent line array 3 dB per octave frequency response roll off from the array. (This on-axis frequency response fall off is in addition to the normal 3 dB per doubling of distance reduction because of near field operation). One can address the 3 dB roll off issue by using measurements at distances within the expected listening distances from the array. The designer can then use these measurements to more closely equalize the line array's response. Thus the crossover can be modeled and derived with these measurements so that the frequency response slope is equalized for the specific listening range. For example, with the crossover optimized for a 4 m (13.1') listening distance, performance would be optimized within a +/- 3 dB window between 2 to 8 m (6.6' to 26.3') distance from the array.

The horizontal dispersion of the individual drivers in a vertical line array is identical to that of a single driver in the line. In a vertical line array nothing in the design alters the horizontal characteristics of the drivers. The resultant response of the array can be approximated by multiplying the known directional response of the sources by the directional characteristics of the array of these sources. It should be noted that if the horizontal response of the individual driver is mediocre, then the resultant line array performance would be negatively impacted. Likewise, a driver with wide horizontal dispersion will continue to have excellent performance in the array.

Overall Array Sound Pressure Level and Impedance

The driver connections in a line array determine the overall impedance of the speakers and connected to attain the resultant sound pressure level of the speaker. Individual drivers are connected in series and parallel arrangements. For drivers that have sound radiation patterns that overlap other drivers in the line there is a net increase in the overall sound pressure level (SPL) results. For example, two speakers connected in parallel and mounted within a wavelength center-to-center spacing would yield up to a 6 dB increase in SPL—3 dB from the increase in acoustical energy and 3 dB from the reduction in impedance. Conversely, series connection of two speakers maintains the same SPL of an individual driver but doubles the impedance of the pair. In a line array various combinations of series and parallel connections can be used to give choices for the overall impedance and SPL values.

The nominal impedance of a line array is computed by calculating the series and parallel combination of impedances. That is, the impedance of each series connected branch is added and then the parallel connections combined into the nominal impedance. Both the acoustic response and the resultant nominal impedance of the overall system must be considered.

While ultimately the SPL of the speaker will be measured, in the development process you can compute the system sensitivity (or efficiency) impact of a line array. First, assume that an individual driver in the line has a known SPL value. Next assume that the drivers in the line have overlapping acoustical radiation patterns and are spaced within a wavelength center-to-center from each other as stated in Table II. Thus, the acoustical improvement (efficiency gain) at 1 watts, 1 meter distance is given by:

$$\text{Efficiency Gain} = 10 \cdot \log(\text{Number of Drivers Driven})$$

while the sensitivity gain or loss at 2.83v, 1 meter is:

$$\text{Sensitivity Gain/Loss} = 10 \cdot \log(\text{Nominal Driver Impedance/Nominal Array Impedance})$$

If the nominal array impedance is less than the individual driver impedance, the array sensitivity increases or is a gain. If the array impedance is greater than the individual driver impedance, then the sensitivity decreases or becomes a loss.

Hence, for the overall system

$$\text{System Efficiency} = \text{SPL} + \text{Efficiency Gain}$$

$$\text{System Sensitivity} = \text{SPL} + \text{Efficiency Gain} + \text{Sensitivity Gain/Loss}$$

For example, consider a case wherein we have 12 drivers connected in parallel groups of 2, 3, 3, and 4 in series. Each individual driver is 8 ohms impedance and has an SPL of 85 dB. Hence, the efficiency gain, total impedance, and sensitivity gain are:

$$\text{Efficiency Gain} = 10 \log 12 = 10.79 \text{ dB}$$

$$\text{Total Impedance of the Combination} = 1 / (1/16 + 1/24 + 1/24 + 1/32) = 5.65 \text{ ohms}$$

$$\text{Sensitivity Gain} = 10 \log (8/5.65) = 1.51 \text{ dB}$$

Hence, the sensitivity of the array is:

$$\text{System Sensitivity} = 85 + 10.79 + 1.51 = 97.3 \text{ dB.}$$

To assist the computation of the sensitivity gain for other array combinations you can use the results from Figure 11. Depending upon the number of drivers and nominal impedance, one can easily implement line arrays that yield an array sensitivity which is 10 dB or greater than the sensitivity of the individual drivers.

Because of the 3 dB per doubling of distance sound decrease for near field line arrays, their in-room sensitivity has an additional advantage versus point source speakers. For example, let's compare two speakers--a line array and a point source--that both produce 94 dB SPL at one meter. At 4 m (13.1') distance the point source speaker (remember 6 dB per doubling of distance decrease) will produce 82 dB SPL while the near field array will supply 88 dB SPL at the same distance. Thus, the line array at 4 m is equivalent to a point source rated at 100 dB SPL. When combined, the 10 dB or greater array sensitivity improvement plus the 6 dB advantage because of the lower in-room reduction of the sound can make a line array >16 dB more efficient than a point source at 4 m.

One of the additional benefits of the array's sensitivity increase is that for the same SPL the individual drivers in the array are operated at much lower drive level which reduces distortion levels. Lower distortion will enable increased dynamics with associated clarity. If small mid-bass woofers are arrayed both bass and mid-range response benefits from the increase in overall sensitivity and additional headroom is available. The small woofers have very little moving mass so that the transient response is immediate and snappy.

As stated earlier, if planar or ribbon drivers are arrayed in the tweeter line, their limited vertical dispersion beyond their length will influence their overall SPL. Thus paralleled combinations of these drivers may not acoustically increase the overall SPL of the resultant array. Hence, the sound emitted may only maintain the SPL consistent along the length of the line. Thus, the overall system sensitivity is equal to the level of an individual ribbon for the same impedance level. Lower overall array impedance would increase the system SPL versus an individual tweeter while higher array impedance reduces the overall SPL. One example is if 8 ohms ribbon tweeters are arrayed such that the resultant array impedance drops to 4 ohms, then the SPL for the array is 3 dB higher than an individual element.

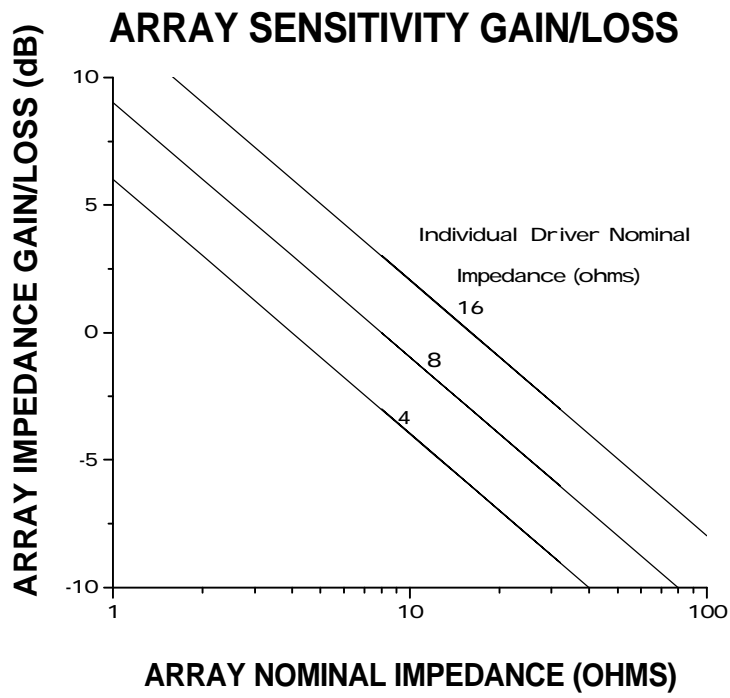
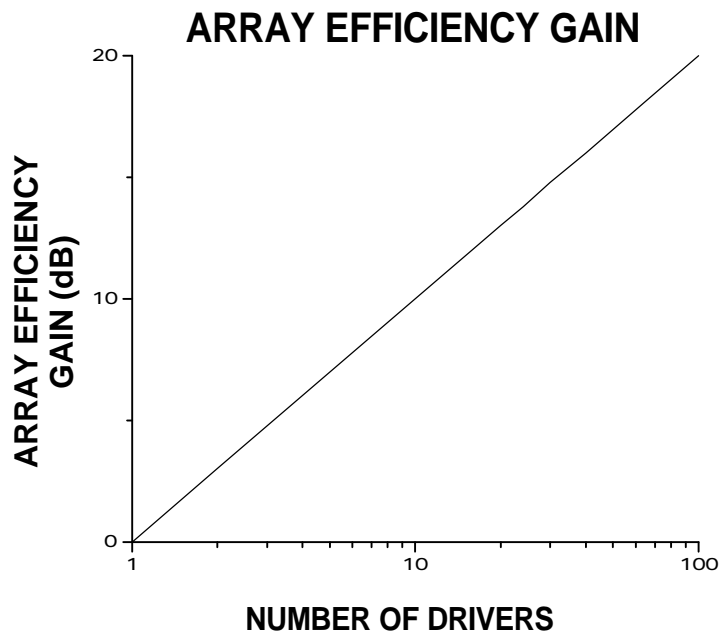

Figure 11. Array Efficiency Gain and Sensitivity Gain/Loss

Application of Power Tapering

Power tapering was first applied to line arrays by several researchers (see [3] and [7]) to reduce the side lobe levels in the far field for sound reinforcement applications. Other workers (see [8] and [9]) have pointed out benefits of power tapering for near field applications. Power tapering is effective for sound radiations that overlap and is accomplished by variation of the power feed to the drivers in a line array. The tapered power feed is symmetrical about the center of the array with the drivers in the center of the array fed more energy and the power tapered or reduced toward the ends of the line.

One concern with near field line arrays is the sound variability for listeners both close to the speakers and those farther removed from the array. If each driver is fed uniformly (equal power) across a flat baffle board and have overlapping sound fields, the various drivers in the woofer line array will have different sound paths to the listener. The drivers at the top and bottom of the array emit sounds that traverse a longer path to the listener. These sounds may interfere with the sound emitted from drivers in the array center that have a shorter distance to reach the listener. Essentially, the sound waves arrive at the listener at slightly different times. This effect is primarily an issue in the mid range and higher frequencies where directional clues are more apparent to the listener. At lower frequencies the path lengths are longer so that sound imperfections are less apparent to the listener. If listeners move away from the array, the image seems to bloom and grow in height. As an example of this effect, let us assume a two meters high line array and that the listener is seated at 4 m (13.1') distance with their ears one meter (3.3') above the floor, i.e., at the array center. Therefore, the path length difference to the listener from the top vs. the center of the array is 123 mm (4.8"). This difference translates to as much as 0.35λ at 1000 Hz and 0.7λ at 2000 Hz.

One solution to mitigate this effect is to mount the drivers on a concave curved baffle board so that the listener hears sound that travels equal distance from all of the speakers. Unfortunately, a curved baffle approach would have a specific sweet spot that will limit speaker placement and listening position possibilities in the room. A second solution is to roll-off the outer drivers in the line as a function of frequency, i.e., low pass filter the outer drivers. Effectively, this power shading technique varies the height of the line-- appropriately shortens or lengthens as frequency changes--so that optimum performance is maintained. But this arrangement adds complexity and may generate phase shifts that would be audible.

Another solution for a flat baffle line array, which will maintain the line array effect yet adapt for the perception of different sound path lengths, is to vertically power taper the sound wave which emerges from the array. We achieve the power tapering by feeding slightly different power levels to the various drivers in the woofer array. Louder sound levels are produced from the center of the array versus the sound level from the ends of the array. Furthermore, at higher frequencies these sounds will arrive at the listening position sooner than sound from the outer portions of the array. The human ear will give precedence to first arrival sounds and can be further biased if the early arrivals are louder than subsequent sounds. This effect is also known as the Haas Effect. For lower frequencies additional emphasis of the ceiling/floor/side wall reflections will fill any perceivable sound level differences in the vertical plane. But in the mid-range as any room enhancement is minimized, the power taper in the vertical plane will lessen any incoherency from the array ends or reflections. If tapering is taken to the limit, the sound image will trend toward a point source. Experience has shown that a slight power taper

(less than a 2 to 1 ratio) will improve the sound (i.e., reduced sound bloom) with minimal impact to the overall line array operation.

Example of Driver Combinations for a Typical Line Array Application

As an example of various driver combinations, consider a line array that has 12 woofers (each 8 ohms nominal impedance) and 6 tweeters (each 8 ohms). Furthermore, we will specify that the resultant array will have overall impedance greater than 4 ohms and have vertically symmetrical connections. We also will select configurations that have 4 to 12 ohms overall impedance. Power tapered connections are specified to have power that is highest in the center of the array and decreases as you approach the ends of the array. The tapered connections approximate a linear amplitude function across the array. Hence, for tapered connections power peaks at the center of the array and rolls off as you go to the ends of the array. This connection should enable the listener to hear a more coherent sound because the largest signal comes from the center of the array.

The various possibilities include uniform and tapered feeding configurations for the 12 woofers and 6 tweeters are illustrated in Figure 12. Note that for the 12 woofers case that the 4 parallel group combinations will have a slight sensitivity edge versus the groups that have only 3 parallel paths. You can also use power tapering to better equalize the sensitivity of the woofer and tweeter lines. If you wish to use 6 tweeters then you have three possibilities with the first two for uniform power and the last one for tapered power. Again the combinations have different impedances so one may prefer the ability to adjust the resultant impedance so that the driving amplifier is optimized.

Summary and Listening Impressions

A near field line array provides a different listening experience versus point source speakers. Among the distinctions that characterize line arrays are:

- Near constant sound levels throughout the listening room
- A wider soundstage
- An image 'sweet area' and not an 'sweet spot'
- Recreates live event sound dynamics

One observation from in-room listening to line arrays is that the stereo sound stage is very wide with a large side-to-side and front-to-back sweet spot. When first heard this enhancement of the stereo image area is in stark contrast to listeners who are familiar with pin-point sweet spot listening from point source speakers. Again the broaden image area is a line array manifestation as the near field sound fall off versus distance from the speakers is less for both side-to-side and front-to-back directions within the room. As you move within the room you can hear the opposite speaker when you are a few feet in front of the nearest speaker. With a good line array system you can walk-up beside the speakers and hardly sense that they are producing the sound that you hear. In a way, near field line arrays will redefine your listening experience. Line arrays can reward the listener with more enjoyable music.

12 Woofers and 6 Tweeters Line Array Combinations

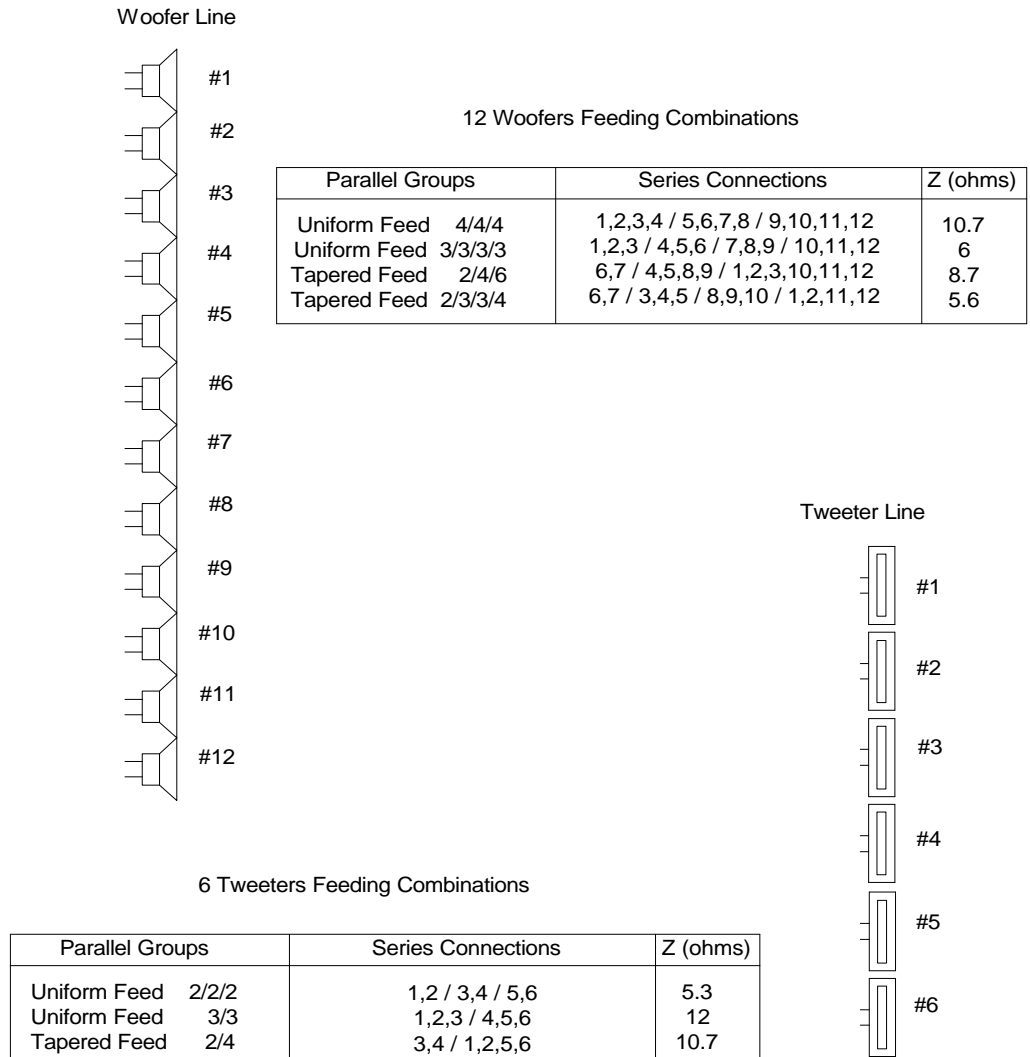

Figure 12. Line Array Combination Example

Line Array References

- [1] M. Urban, C. Heil, and P. Bauman, "Wavefront Sculpture Technology", presented at the 111th AES Convention, New York, September 21-24, 2001.
- [2] C. Heil, and M. Urban, "Sound Fields Radiated by Multiple Sound Sources Arrays", presented at the 92nd AES Convention, Vienna, March 24-27, 1992.
- [3] M. Ureda, "Line Arrays: Theory and Applications", presented at the 110th AES Convention, Amsterdam, May 12-15, 2001.
- [4] J. Eargle, D. Scheirman, and M. Ureda, "JBL's Vertical Technology: Achieving Optimum Line Array Performance Through Predictive Analysis, Unique Acoustics Elements and a New Loudspeaker System", presented at the AES Convention, September, 2000 and also available from:
<http://www.jblpro.com/vertec1/VerTec%20WP%202.3.pdf>
- [5] M. Ureda, "'J' and 'Spiral' Line Arrays", presented at the 111th AES Convention, New York, September 21-24, 2001.
- [6] S. Lipshitz and J. Vanderkooy, "The Acoustics Radiation of Line Sources of Finite Length", presented at the 81st AES Convention, Los Angeles, November 12-16, 1986.
- [7] P. Taylor, "The Line-Source Loudspeaker and Its Applications", Vol. 44, No. 3 British Kinematography (J. Brit. Kinematograph Soc.), vol. 44, 1964 March.
- [8] D. Smith, "Discrete-Element Line Arrays – Their Modeling and Optimization, J. Audio Eng. Soc., vol. 45, no. 11, 1997 November.
- [9] G. Augspurger, "Near-Field and Far-Field performance of Large Woofer Arrays", J. Audio Eng. Soc., vol. 38, no. 4, 1990 April.
- [10] E. Geddes and L. Lee, Audio Transducers, p.68. 2002.
- [11] M. Ureda, "Pressure Response of Line Sources", presented at the 113th AES Convention, Los Angeles, October 5-8, 2002.
- .